



- Document Destruction

- Multi Waste Shredding

- Tyre Shredding

# EV60E

## PERFORMANCE CHARACTERISTICS:

30 Kw/ 40 Hp Maximum Power

28—30 Rpm Cutter Speed Rotation

12, 16 or 32 mm Shred Width

608/512 mm x 375 mm Cutting Chamber Opening

18,9 m/min Cutting Speed

2000 Kg per hour\*

3000 Kg per hour\*\*

76 DbA @ 1 meter (no load)

Recommended In-feed: Bin Tipper or Conveyor Belt

Recommended Out-feed: Storage Bin or Conveyor Belt

Electronic Controls

Stationary and Mobile Applications

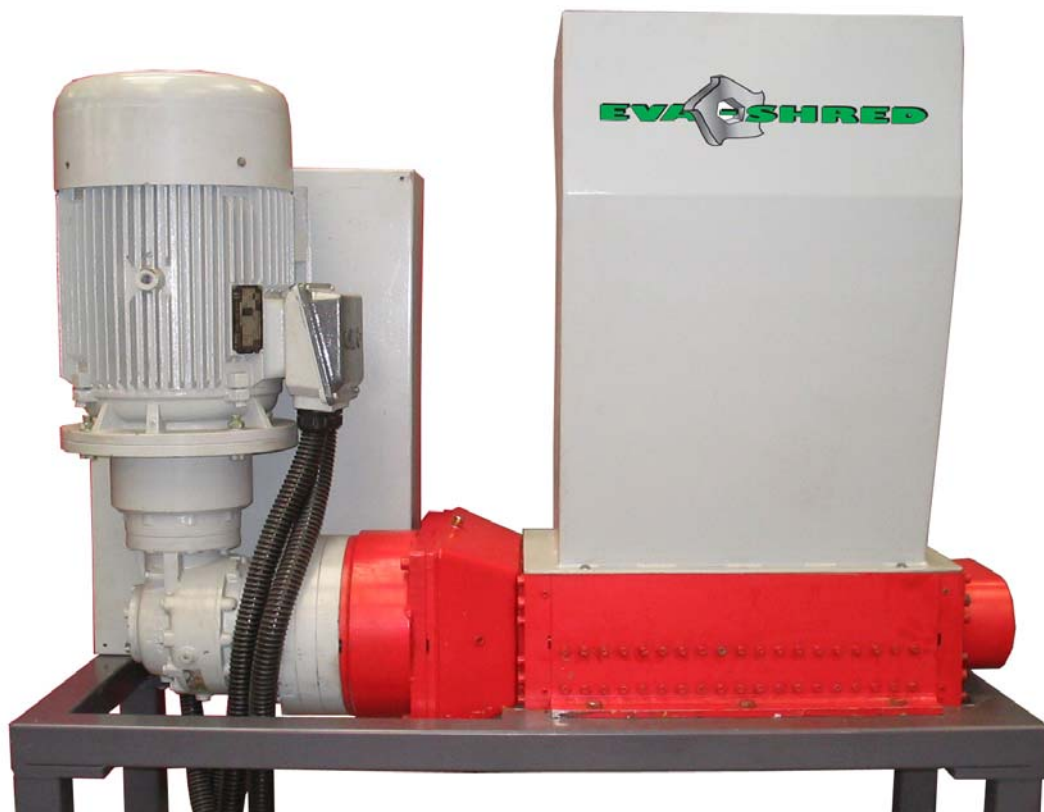

\* Normal Office Paper Under Ideal Conditions

\*\* Normal Collection of Passenger Tyres Under Ideal Conditions

Specifications are subject to change without notice. Contact your nearest distributor/ agent for up-to-date specifications prior to purchase.

# EV60E

## TECHNICAL SPECIFICATIONS:

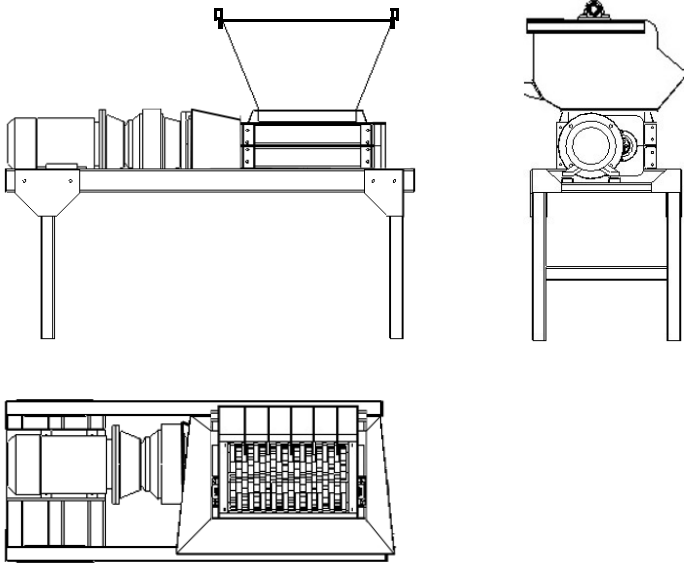

### PHYSICAL DIMENSIONS:

Total Height:	2180 mm
Total Length:	2240 mm
Total Width:	760 mm
Ground Clearance (underneath shredder):	810 mm
Ground to Hopper Entrance Lip Height:	1815 mm
Hopper Opening:	1030 x 800 mm
Shredder Chamber Opening:	608/ 512 x 375 mm

<b>SHREDDER NAME:</b>	<b>EV60E (Electric)</b>
Number of Motors	1 x 30Kw
Number of Gearboxes	2
Type of Gearboxes	1 x Planetary Reduction, 1 x Splitter
Cutter Width	12mm, 16mm or 32mm
No. of Hooks per cutter	3
Cutter Diameter	200mm
Distance between Shafts	165mm
Hex Shaft Diameter	77mm AF
Critical Shaft Length	608mm (Tyres), 512mm (Paper)
Cutter Chamber Opening	608 / 512mm x 375mm
Cutting Chamber Height	250mm
Hopper Height	1000mm
Stand Height	930mm
Total Height	2180mm
Floor Footprint Dimensions	2240mm x 760mm
Weight	1400 Kg
Capacity/ Throughput Rate	2000 kg per hour*/ 3000 kg per hour**
Cutting Tip Force	16000 Kg/ 35200 lbs per meter of shaft length

\* Normal Office Paper Under Ideal Conditions

\*\* Normal Collection of Passenger Tyres Under Ideal Conditions

Specifications are subject to change without notice. Contact your nearest distributor/ agent for up-to-date specifications prior to purchase.